

SILENCE 



USER MANUAL



***NOMAD***

(V002)

-14/09/2023



## HELL SILENCER

Introducing the new **NOMAD**, an inverter with which you can get the most out of your *Battery Pack (BP)*. Now, not only can you get around the city with your electric vehicle while being able to charge it wherever and whenever you want, you can also power up many other devices.

Everything that requires electricity to run can be powered <sup>1</sup> thanks to the inverter that SILENCE has developed for you. Thanks to its backpack design, the **NOMAD** is portable (as is your removable battery), allowing you to use both wherever you are.

All you have to do is connect the BP to the **NOMAD**, along with the device you want to use. You can connect different household appliances or electrical devices, be it a mobile phone, a laptop, a coffee maker, a lamp, a TV, a fan, a portable refrigerator, a toaster... up to a maximum output of **3000 W**, thanks to its **two 220 V alternating current outlets** (2 Schuko connectors) plus its **USB output of 5 V of direct current**.

If the removable *trolley-style BP* made it possible to **break down the barrier of the charging point**, the **NOMAD** does the same with the barrier of the **point of consumption**.



- **Energy IN:** On the one hand, you will find the energy with which to power the battery pack which, at SILENCE, we call “**Energy IN**”. You can charge your battery directly from the mains with a normal plug, or get a unit charged at one of our **Battery Swapping Stations (BSS)**<sup>2</sup>.
- **Energy OUT:** On the other hand, we have the “**Energy OUT**”, which is everything that works thanks to the energy that the battery provides, in other words, all the applications of the battery pack: energy for your SILENCE vehicle, or for whatever you connect to your **NOMAD**<sup>3</sup>.

<sup>1</sup> According to the technical specifications of the device.

<sup>2</sup> Quick charging devices other than those supplied by SILENCE should not be used in any circumstances, as the warranty may be voided.

<sup>3</sup> Inverters other than those supplied by SILENCE should not be used in any circumstances, as the warranty may be voided.



## ABOUT THIS MANUAL

Read this manual carefully, and pay special attention to the safety instructions. It contains everything you need to know as a user of a **NOMAD** inverter.

The information contained in this manual is the most recent available for this model as of the date of approval for publication/printing. Scutum Logistics S.L. reserves the right to make any changes at any time and without prior notice, without incurring any obligation whatsoever. No part of this manual may be reproduced without written permission. You can consult the latest version in [USER MANUALS](#), or by scanning the following QR code:



The images in this manual may show optional connected devices (not included as standard), as well as elements in a colour that may differ from the real one.



## OFFICIAL SERVICE CENTRE NETWORK

If you need extra support, you can always go to any official SILENCE Service Centre. You will find the map with our network of workshops by clicking on the [OFFICIAL SERVICE CENTRES](#) link or by scanning the QR code:





## CONTENT OF THIS MANUAL

HELLO SILENCER.....	2
ABOUT THIS MANUAL .....	3
OFFICIAL SERVICE CENTRE NETWORK .....	3
CONTENT OF THIS MANUAL .....	4
SAFETY .....	5
1) Safety warnings .....	5
2) Disclaimers .....	6
3) Fire prevention measures .....	7
4) First aid measures .....	7
<b>GENERAL COMPONENTS AND OPERATION .....</b>	<b>8</b>
1) General components of the NOMAD .....	8
2) General components of the battery pack .....	11
3) NOMAD connection to the BP.....	13
4) Considerations.....	15
5) Good practices on battery charging and the use of the NOMAD.....	17
6) Good practices to ensure proper battery maintenance.....	17
<b>TECHNICAL SPECIFICATIONS.....</b>	<b>18</b>
1) Inverter Specifications.....	18
2) Battery and Charger Specifications .....	19
<b>DISPOSAL AND RECYCLING .....</b>	<b>19</b>
<b>CLEANING.....</b>	<b>20</b>
<b>RESOLUTION OF INCIDENTS.....</b>	<b>21</b>
<b>PRODUCT WARRANTY .....</b>	<b>22</b>



## SAFETY

### 1) Safety warnings

The battery can be a **VERY DANGEROUS** product (risk of death) **when it is out of the vehicle**:

- It should always be **transported on its wheels**, at a slow speed (**max. 3 km/h**), slower than the speed reached by an average person when walking.
- **Any mistreatment of the battery must be avoided**, such as hitting or bouncing it, rolling it over cobblestones, stairs or holes, dropping it (downstairs, for example), as this could cause it to catch fire. Avoid all contact with water.
- **If there is any indication or you suspect the *Battery Pack* has been used improperly** or has fallen, do not plug it in. Call a SILENCE Official Service Centre, as this could be **LIFE THREATENING**.

Similarly, regarding the **NOMAD**, the following must be taken into account:

- Insert only **Schuko** or **USB** connectors into the corresponding sockets on the device.
- When disconnecting the inverter from the *Battery Pack*, do so by **pulling the handle of the connector**. Never pull on the cable.
- Similarly, when disconnecting any cable from the inverter sockets, **do so by holding the device and the connector to be removed**.
- Do not touch the main connector's outlets. **Also avoid having any part of the device come into contact with water**.
- Respect the power limitation (**3000 W**). If it is exceeded, the inverter itself will beep continuously and will stop working until the maximum admitted power is no longer exceeded. You will need to restart it (turn off and on using the red button).

In general, in order to **prevent injuries, burns or electric shocks**:

- Never disassemble the battery pack or remove its caps. **Only authorised personnel are permitted to do so** (the same applies to the inverter).
- **Keep children away from both elements**.
- Do not perforate or bump, e.g., when using lifts, do not expose it to liquids or flames: the generation of excess heat may lead to fire, which could be very dangerous.



## 2) Disclaimers

- **The unsupervised use of the NOMAD by minors is prohibited:** the high voltage of the sockets poses a risk of electric shock.
- **Do not twist the cables:** The use of broken cables may cause an electric shock, a short circuit or fire.
- **Do not disassemble or modify the NOMAD:** Short circuits may occur and, as a consequence, fire and electric shocks.
- **Do not place rods or other metal objects into the ventilation openings or other openings:** This could involve touching internal components and cause electrical shock and/or injury.
- **Plug the plugs completely into the sockets:** If they are not fully connected, this can cause electric shocks, overheating and even a fire. **Do not use damaged pins or loose sockets.**
- **Keep the NOMAD away from fire:** Also keep away from flammable substances, including volatilized fuel.
- **Do not handle the NOMAD with wet hands:** Risk of electric shock.
- **Do not damage the power outlets:** Do not cut, twist, put weight on or pull the cables or make any modifications to the **NOMAD** components.
- **Do not connect in a loop:** Do not try to power the battery through the **NOMAD** connected to it, nor should you short-circuit one current output with another.
- **The battery should not be charged and discharged at the same time:** During the battery charging process, it is not possible to power any other device.
- **Do not use the NOMAD in excessively hot and humid environments:** A spill can cause electric shock or fire.
- **The NOMAD has not been tested for use with medical equipment.**



### 3) Fire prevention measures

In the event that smoke begins to come out of the battery, it is of vital importance that you urgently call the fire department (**RISK OF DEATH**) and remove it from the closed space in which it may be found.

The vehicle cannot explode, so there is no problem with transporting it to a safe location (at a distance of at least 15 m from any exposure: other vehicles, other batteries...). Once in a safe area, call the emergency services who will handle the situation.

#### Extinguishing/suppression devices:

- **Fire extinguishers:** Type D, CO2, dry chemical.
- **Water:** in the event the vehicle/battery is not plugged in or near other batteries.

### 4) First aid measures

In case of battery rupture, smoke or fire, evacuate personnel from the contaminated area and provide the maximum amount of ventilation to clean out any fumes. In any case, seek medical attention.

#### Specific measures in case of (regarding smoke):

- **Contact with eyes:** Flush with plenty of water (eyelids open) for at least 10 minutes.
- **Contact with skin:** Take off all contaminated clothing and wash the affected area with plenty of soap and water for at least 15 minutes. Do not apply grease or ointments.
- **Inhalation:** Go outdoors and ventilate the contaminated area. Administer oxygen or artificial respiration if necessary.



# GENERAL COMPONENTS AND OPERATION

## 1) General components of the NOMAD

The general components that are part of your new **NOMAD** are:







To use the **NOMAD**, first of all, you will need to rest it on a flat and stable surface and open its 3 flaps, in the following order:

- 1 Unfold the top flap, **exposing the fans**, free of obstacles.  
→ **⚠ There is a risk of overheating if this is not done!**
- 2 Unfold the main flap and fold it in 3 sections, adhering it to the side of the **NOMAD** using the circular Velcro.
- 3 Unfold the bottom flap, exposing the power sockets.

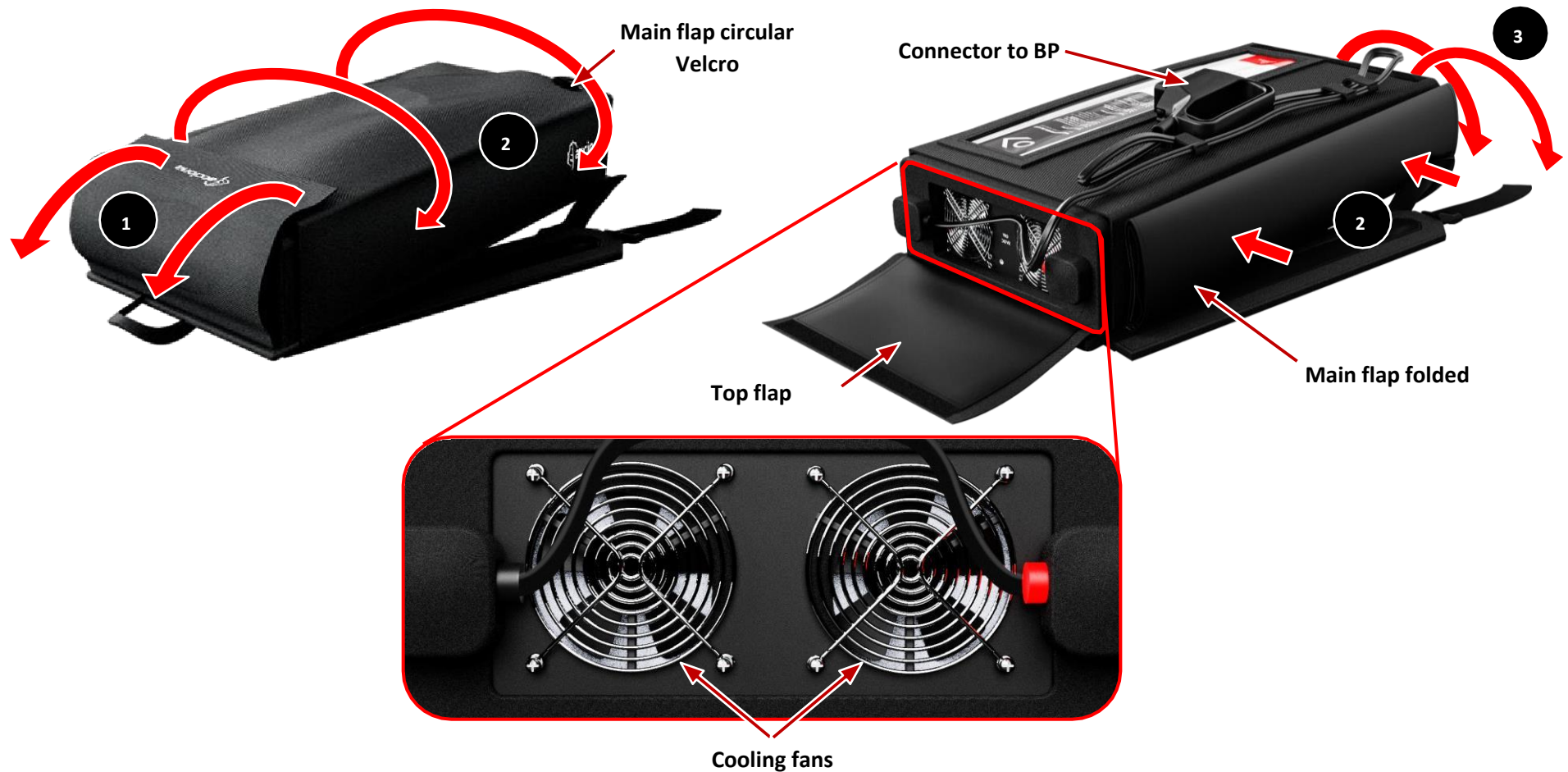



Seen from the bottom flap side:

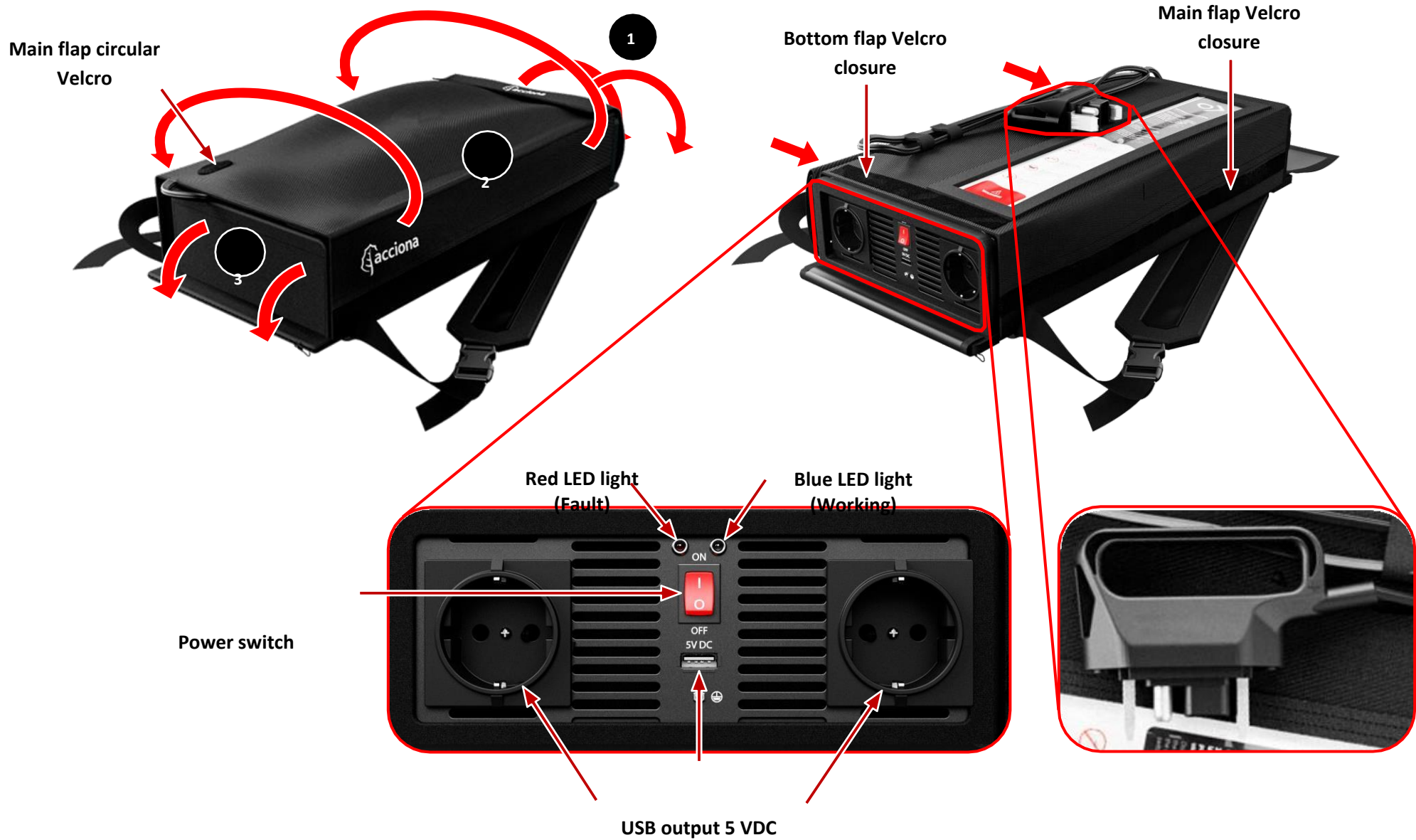



## 2) General components of the battery pack

The general components that are part of the **Battery Pack (BP)** are:









**Light ring**

In order to know the state of charge of the battery, there is an LED light ring on one side of it that will provide us with this information, regardless of whether the battery is inside or outside the vehicle (if the vehicle's ignition is on or the NOMAD is on, the ring will not light up under any circumstances).



	BP's WITH GREEN COLOUR CODE	BP's WITH REDDISH COLOUR CODE	
<b>BP NOT CHARGING</b>	By touching the inside of the ring lightly, it will display the following:		
	RED and BLUE light trails, each moving around the ring in opposite directions. Following this, it will be shown in TURQUOISE.		One REDDISH and one WHITE light trail.
	Then the percentage of remaining charge will be indicated momentarily, by means of:		
	A portion of the ring lit up in GREEN (or the entire ring, if the charge is at 100 %).		A portion of the ring lit up in a REDDISH colour (or the entire ring, if the charge is at 100 %).
	In the case of low battery charge:		
	The entire ring will be displayed in RED.		The entire ring will be displayed in YELLOW.
<b>BP CHARGING</b>	While the battery is charging, it will alternate between:		
	A GREEN light trail that moves around the ring and a portion of the ring that is lit up, showing the total percentage of the battery that is charged.		A REDDISH light trail that moves around the ring with a portion of the ring that is lit up, showing the total percentage of the battery that is charged.
	Once it reaches 100 %, the ring will display:		
It will be all GREEN with a BLUE light trail moving around the ring while it is still plugged in.		It will be all REDDISH with a WHITE light trail moving around the ring while it is still plugged in.	



### 3) NOMAD connection to the BP

#### How to connect it

1. Connect the **NOMAD** main connector (*Multicontact male*) to the BP (*Multicontact female*):

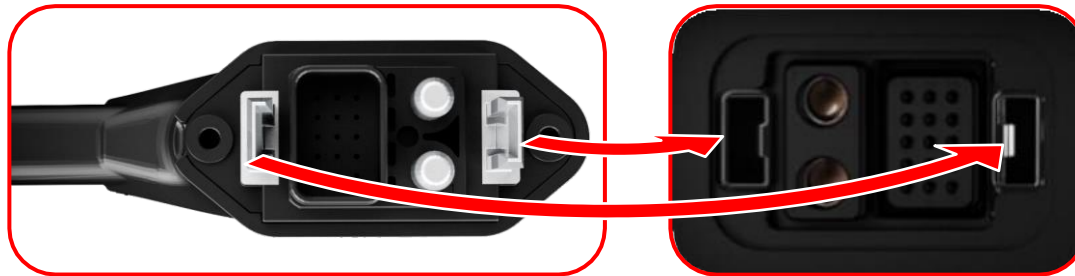

2. Turn on the inverter with the red switch (“I” / “ON” position):



3. You will hear a beep. Wait for it to finish.
4. Connect the desired plugs to the corresponding sockets (according to the total power limitation, **3000 W**):

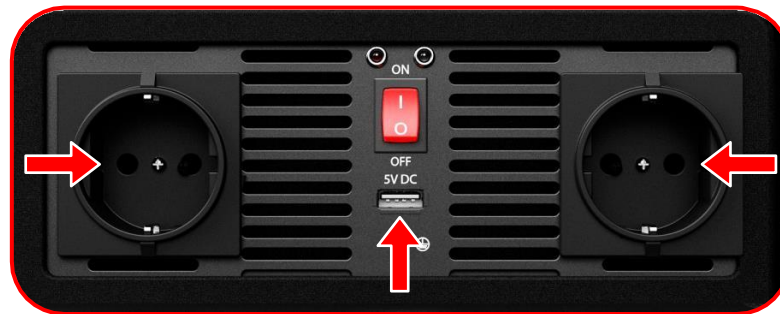



## How to disconnect it



**WARNING! Carry out the disconnection process exactly in the indicated order, risk of electric shock.**

1. Disconnect any item connected to the inverter's plugs:

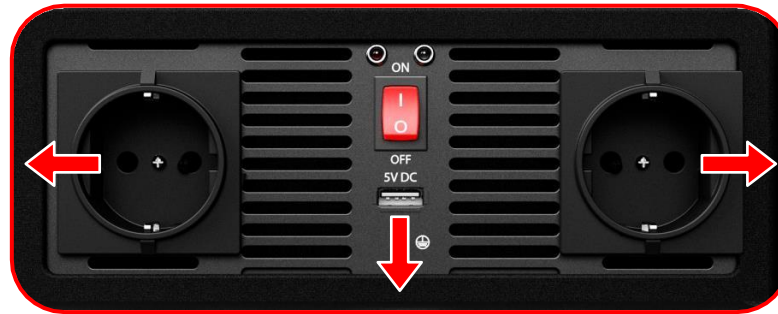

2. Disconnect the BP connector:

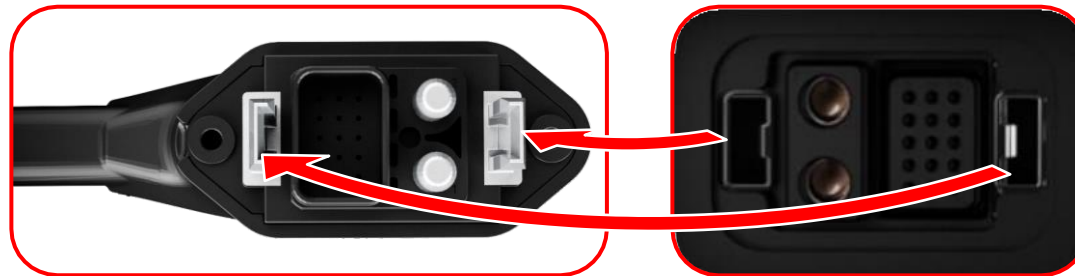

3. Turn off the inverter using the red switch ("0" / "OFF" position):





## 4) Considerations

### BP activation

In order for a Battery Pack to be able to supply power via the **NOMAD**, this option must first be activated at an official SILENCE Service Centre.

Contact your nearest Service Centre so that your BP or BP's can be used with your new NOMAD inverter.

### Charge level

When the BP is about **5-10 % charged**, the inverter stops working.

Monitor the charge level by means of the LED ring. If the level is insufficient, the battery should be recharged before use with the inverter.

If the battery is below **0 °C** or **above 50 °C** (due to improper use), it will not charge.

## IMPORTANT!

Charge the battery fully once every 30 days to ensure the validity of the warranty\*.

**If it is connected** at a low temperature, an internal heater will turn on until it reaches a suitable temperature for charging (**in the case of battery units with this element activated**). This heater works when plugged into the mains and allows the power to be transferred at the right temperature. However, this has an impact on the charge time, which will take longer than if the temperature conditions were within the normal range.

For cold regions and seasons, we recommend keeping the battery plugged into the mains so the heater can warm the cells and keep them at the right temperature for the inverter to be used normally.

**\*To ensure the validity of your battery's warranty, you must charge it fully (to 100 %) at least once a month.** If you know you will not be using it for a while, it is very important to leave the battery with enough charge so that it does not drop to critical levels. Batteries that fall below a certain range of voltage no longer work on their own, meaning they cannot be charged and must be taken to an Official Service Centre.



## Temperature

### NOMAD temperature

The inverter works in a temperature range between **-10 °C and 50 °C**.

### BP temperature

The battery's operating range, meanwhile, is between **-10 °C and 60 °C**. The performance of the lithium cells may vary depending on the temperature. The charger does not charge the battery if the cell temperature is below **0 °C** or above **50 °C**.

This battery has a system that controls and stabilises the voltage and temperature of the cells. To avoid critical situations, the safety systems limit battery use if the cell temperature exceeds safe levels due to overheating or overcooling.

Depending on the situation, the following actions should be taken:

- **Low temperature:** The battery will not function in optimum conditions; store it in a warmer place and charge it (if it has an internal heater installed and activated).
- **High temperature:** The battery cannot deliver more power, due to intensive use; unplug the inverter and let it cool down.

## Range

The battery's range is influenced by many factors, including the **power of the devices** connected to it through the **NOMAD**, the **time** they remain connected (the more power, the less time the battery charge will last), or the range of temperatures in which it works (operating far outside the optimal range can reduce it).

The **Light ring** offers an indication of the remaining range, allowing you as a user to have control over the energy of your *Battery Pack*.





## 5) Good practices on battery charging and the use of the NOMAD

Battery charging or discharging using the NOMAD must be carried out following these recommendations:

- When using the devices at home, place them in isolated and ventilated areas such as garages, laundry rooms, storage rooms or patios.
- Do not charge/discharge the battery in the rain when the battery is outside the motorbike.
- Do not charge/discharge in areas of passage or at the entrance to the home.
- Keep the devices away from hot elements or elements that can cause heat, such as radiators or stoves.
- Keep the devices away from mobile elements, such as vehicles or doors, preventing them from potentially being hit.
- Keep the devices at a safe distance from any other element, such as tables, cabinets, chairs, shelves.
- Regularly monitor the devices during the charging/discharging process.

## 6) Good practices to ensure proper battery maintenance

**The battery has a maximum service life of 1,000 cycles, maintaining 80 % of its capacity if it is serviced according to the warranty and a range of good practices are followed:**

- When using the BP in the vehicle, avoid using the SPORT mode excessively, trying to use the CITY mode as long as possible (reason: avoid aggressive driving with continuous sudden accelerations).
- Make sure that the battery is not fully discharged; charge it when its charge level is at around 25 % of the SoC, thus avoiding complete charge cycles and limiting the depth of discharge.
- Keep the battery at a temperature of 20-30 °C and ensure that the battery operates outside this range for as little time as possible. The battery will deteriorate more easily when it is operated outside this temperature range, losing its properties.
- Whenever possible, use the internal charger for charging, and avoid using quick chargers continuously.



# TECHNICAL SPECIFICATIONS

## 1) Inverter Specifications

Weight	7.35 kg
① Height	9.5 cm
② Width	21.5 cm
③ Length	49.5 cm
Nominal power	3000 W
Peak power	6000 W
Input voltage (Multicontact)	That of the Battery Pack
Output voltage (Schuko, x2)	220 VAC
Output voltage (USB port)	5 VCC
Frequency	50-60 Hz
Output wave	Pure sine wave
Soft start	Yes
AC regulation	THD <3 %
Maximum efficiency	94 %
Cooling	Smart fans
Protections	Battery undervoltage
	Battery overvoltage
	Overcharge   Overtemperature   Short circuit
Operating temperature	-10 °C to 50 °C





## 2) Battery and Charger Specifications

Nominal capacity	4.1 kWh	5.6 kWh
Cell chemicals	Lithium-ion cells	
Weight	36 kg	41 kg
Unfolded height	870 mm	
Box height	270 mm	
Wheel width	330 mm	
Box depth	440 mm	
Nominal voltage of the battery	51 VDC	
Storage temperature (not charging)	-20 to 45 °C (max.) / 0 to 25 °C (recommended)	
Operating temperature	0 to 50 °C (charging) / -10 to 60 °C (use, discharging)	
Housing material	Aluminium and PC	
Max. charging current	30 A	35 A
Max. discharge current	160 A	280 A
Type of charger	Onboard 90-240 VAC; 600 W	
Max. internal charger current	~11 A	
Standard charge time	5-7 h	7-9 h

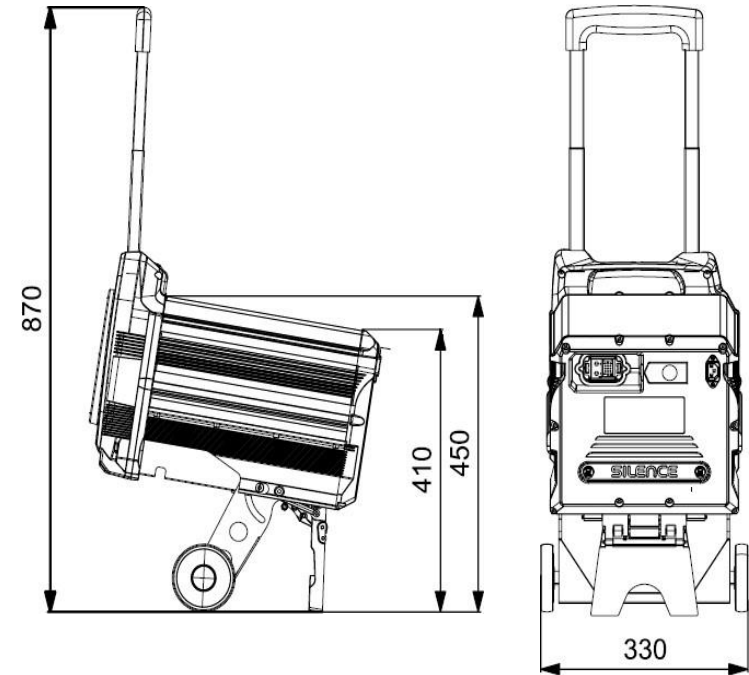

## DISPOSAL AND RECYCLING

Once your SILENCE **NOMAD** has reached the end of its service life, it must be recycled in accordance with the applicable regulations and always respecting the environment. The law prohibits disposing of electronic products in domestic waste containers. Where appropriate, you must go to a green waste collection point, thus reducing its environmental impact.





## CLEANING

The product must be cleaned, taking into account its two parts:

- 1) **Backpack:** use a dry cloth. If you need to clean persistent stains, use a slightly damp cloth, making sure to avoid getting the power outlets, fans and power connector wet.
- 2) **Other components:** use only a dry cloth to clean the power outlets, the fans or the power connector.

It is the user's responsibility to adequately protect the product from any contaminating agent. You should clean it regularly to keep it in good condition.

**WARNING: Do not clean the inverter when it is connected. DO NOT use water to clean the parts that are NOT fabric. Do not clean on top of the logos. Do not use detergents or soaps. Make sure it is completely dry before connecting to the BP.**



## RESOLUTION OF INCIDENTS

All NOMAD products are carefully inspected before delivery to our distributor. Even after the product has been inspected, problems may still occur. The following table provides a guide to identify the problem and, if possible, repair it yourself. If you are unable to resolve the problem, take the NOMAD to the official SILENCE service centre for repair.

INCIDENCE	PROBABLE CAUSE	SOLUTION TO BE APPLIED
AC not working, power indicator off, power failure or alarm sound on	Low battery	Charge battery or use charged battery
AC not working, power indicator off, power failure or alarm sound on	Battery not enabled	Contact technical service
AC not working, power indicator off, power failure or alarm sound on	Battery not working	Use battery in perfect condition
AC does not work, power failure indicator or alarm sound activated	AC overload	Only connect equipment below maximum power
AC does not work, power failure indicator or alarm sound activated	Over-temperature	Switch off and leave to cool



## PRODUCT WARRANTY

As a general rule<sup>4</sup>, this product has a minimum 2-year warranty period (which increases to 3 if established as such in the current legislation of the country in which its sale is registered), counted from the date of delivery and receipt, covering any design and manufacturing defects.

The natural wear and tear of the backpack due to use is not covered by the warranty.

**The warranty will be VOID if:**

- a) The end user has treated the product contrary to regulations or to the warnings expressed throughout this Manual.
- b) The product has been modified or changed in any way or fitted with parts that are not part of the original features (or certified expressly by the manufacturer).

---

<sup>4</sup> Agreements that differ from the warranty terms and conditions above must be confirmed in writing by the manufacturer.

